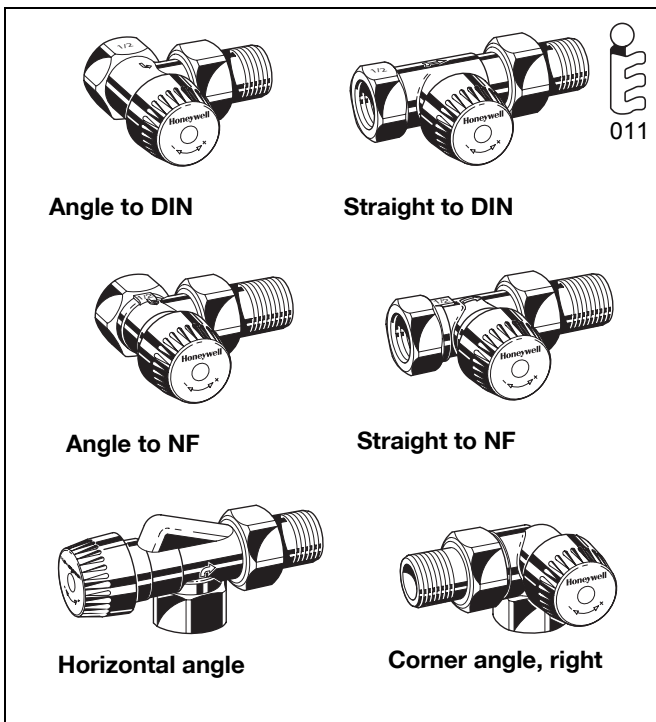


Product specification sheet



Application

Thermostatic radiator valve bodies (TRV bodies) are fitted on the supply or return of radiators or heat exchangers. Together with a radiator thermostat, for example the Thera-4, they control the room temperature by regulating the flow of hot water into the radiator or heat exchanger. The temperature of different rooms is controlled individually and energy is saved.

TRV bodies of this type have quiet operation and are fitted to the supply of radiators on two-pipe systems with medium flow rates. The flow rate can be preset according to system requirements. The valve insert can be replaced while the system is running and without draining using the service tool (see 'Accessories').

TRV bodies of this type are suitable for

- Honeywell radiator thermostats with M30 x 1.5 connection
- Certain Honeywell MT4 actuators
- Honeywell Hometronic HR80 and Roomtronic HR40 actuators

AT-Concept

AT-Concept valves share the same valve housing design. The valve insert can be replaced by any other AT-Concept valve insert, i.e. BB, KV, UBG, SL, VS, FS, FV and SC.

Special Features

- Pre-settable fine-adjustment valve disc
- Tamper-proof presetting, visible when radiator thermostat is removed
- For heating systems with medium flow rates
- With extra position for system flushing
- Quiet operation
- DIN type bodies with dimensions according to EN215, Appendix A, Series D
- NF type bodies with dimensions according to EN215, Appendix A, Series F
- AT-Concept valve housing and insert
- Valve insert can be replaced while system is operating and without draining the system
- Valve opening spring is not in the water
- Standard M30 x 1.5 thermostat connection

Construction

The thermostatic radiator valve body consists of:

- Valve housing PN10, DN10, 15 or 20 with
 - o internal thread connection to DIN2999 (ISO7) for threaded, copper or precision steel pipe on inlet (compression ring fittings see 'Accessories')
 - o external thread connection with union-nut and radiator tailpiece on outlet (Eurocone for DN15)
 - o angle to DIN and straight to DIN bodies with dimensions according to EN215, Appendix A, Series D
 - o angle to NF and straight to NF bodies with dimensions according to EN215, Appendix A, Series F
- Pre-settable valve insert with flush position
- Protection cap
- Union-nut and radiator tailpiece

Materials

- Valve housing made of nickel-plated hot-forged brass
- Valve insert made of brass with EPDM O-rings and soft seals, stainless steel spindle and plastic presetting dial
- Protection cap made of beige plastic
- Union-nut and tailpiece made of nickel-plated brass

Technical Data

Medium	Heating water, water quality to VDI2035
Operating temperature	max. 130 °C (262°F)
Operating pressure	PN10
Differential pressure	max. 200 kPa (2 bar, 29 psi) – max. 20 kPa (0.2 bar, 2.9 psi) recommended for quiet operation
k_{vs} (C_{vs})-value	0.75 (0.87)
Nominal flow	130 kg/h
Body-head connection	M30 x 1.5
Closing dimension	11.5 mm
Stroke	2.5 mm

Identification

- Beige protection cap, 'V' embossed on top of cap
- Beige plastic scale on top of valve insert

Method of Operation

Thermostatic radiator valves enable individual control of room temperature and thus save energy.

The TRV body is controlled by the radiator thermostat. Air from the room passing over the sensor of the radiator thermostat causes the sensor to expand when the temperature rises. The sensor acts onto the valve spindle and this causes the TRV body to close. When the temperature falls the sensor contracts and the spring-loaded valve spindle is opened. The TRV opens in proportion to the temperature of the sensor. Only the amount of water required to maintain the room temperature set on the radiator thermostat can flow into the radiator.

Please note:

- To avoid stone deposit and corrosion the composition of the medium should conform with VDI-Guideline 2035
- Additives have to be suitable for EPDM sealings
- System has to be flushed thoroughly before initial operation with all valves fully open
- Any complaints or costs resulting from non-compliance with above rules will not be accepted by Honeywell
- Please contact us if you should have any special requirements or needs

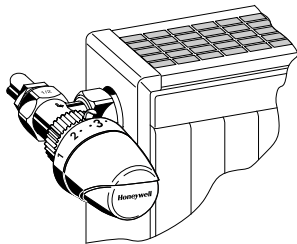
Installation Examples

Fig. 1. Angle

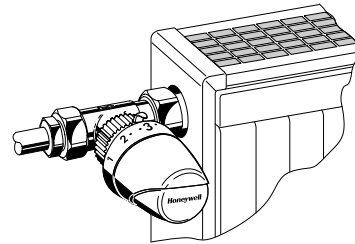


Fig. 2. Straight

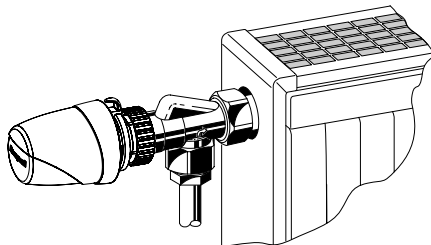


Fig. 3. Horizontal angle

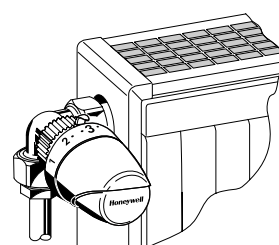


Fig. 4. Corner angle left

Dimensions and Ordering Information

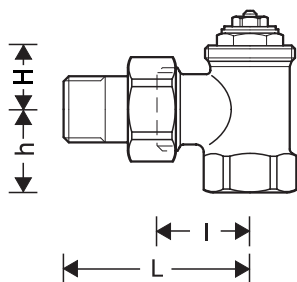


Fig. 5. Angle

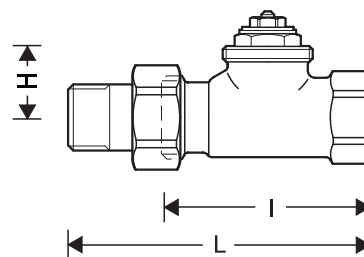


Fig. 6. Straight

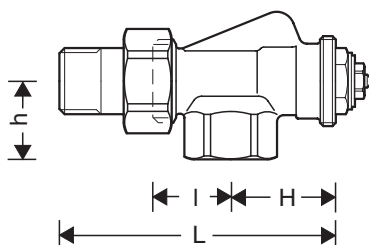


Fig. 7. Horizontal angle

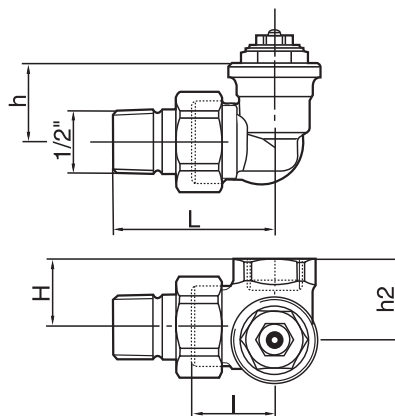


Fig. 8. Corner angle left

Table 9. Dimensions and OS-Nos (OS=Ordering System)


Body type	DN	EN215 certified	$k_{vs}(C_{vs})$ -value	Pipe connection	l	L	h	H	h2	OS-No.
For the supply										
Angle to EN215 (D) (Fig. 5)	10	•	0.75 (0.87)	Rp 3/8"	26	52	22	20	—	V2000EVS10
	15	•	0.75 (0.87)	Rp 1/2"	29	58	26	20	—	V2000EVS15
	20	•	0.75 (0.87)	Rp 3/4"	34	66	29	19	—	V2000EVS20
Straight to EN215 (D) (Fig. 6)	10	•	0.75 (0.87)	Rp 3/8"	59	85	—	25	—	V2000DVS10
	15	•	0.75 (0.87)	Rp 1/2"	66	95	—	25	—	V2000DVS15
	20	•	0.75 (0.87)	Rp 3/4"	74	106	—	25	—	V2000DVS20
Angle to EN215 (F) (Fig. 5)	10	•	0.75 (0.87)	Rp 3/8"	24	49	20	21	—	V2020EVS10
	15	•	0.75 (0.87)	Rp 1/2"	26	53	23	22	—	V2020EVS15
	20	•	0.75 (0.87)	Rp 3/4"	34	66	29	18	—	V2020EVS20
Straight to EN215 (F) (Fig. 6)	10	•	0.75 (0.87)	Rp 3/8"	50	75	—	26	—	V2020DVS10
	15	•	0.75 (0.87)	Rp 1/2"	55	82	—	26	—	V2020DVS15
	20	•	0.75 (0.87)	Rp 3/4"	74	106	—	24	—	V2020DVS20
Horizontal angle (Fig. 7)	10	•	0.75 (0.87)	Rp 3/8"	24	50	22	33	—	V2000AVS10
	15	•	0.75 (0.87)	Rp 1/2"	26	54	26	35	—	V2000AVS15
Corner angle, radiator connection left (Fig. 8)	10	•	0.75 (0.87)	Rp 3/8"	24	53	26	22	26.5	V2000LVS10
	15	•	0.75 (0.87)	Rp 1/2"	24	53	26	26	30.5	V2000LVS15
Corner angle, radiator connection right (Fig. 8)	10	•	0.75 (0.87)	Rp 3/8"	24	53	26	22	26.5	V2000RVS10
	15	•	0.75 (0.87)	Rp 1/2"	24	53	26	26	30.5	V2000RVS15

NOTE: All dimensions in mm unless stated otherwise.

Accessories


Pipe Connections

Compression fitting for COPPER and STEEL pipe.
Consisting of compression nut and compression ring.
For valves with internal thread.

	Valve size	Pipe dimension	Part number	Pcs/ pack
	3/8" (DN10)	10 mm	FIG3/8CS10	1
	3/8" (DN10)	12 mm	FIG3/8CS12	1
	1/2" (DN15)	10 mm	FIG1/2CS10	1
	1/2" (DN15)	12 mm	FIG1/2CS12	1
	1/2" (DN15)	14 mm	FIG1/2CS14	1
	1/2" (DN15)	15 mm	FIG1/2CS15	1
	1/2" (DN15)	15 mm	FIG1/2CS15-10	10
	1/2" (DN15)	16 mm	FIG1/2CS16	1
	3/4" (DN20)	18 mm	FIG3/4CS18	1
	3/4" (DN20)	22 mm	FIG3/4CS22	1


NOTE: Support inserts have to be used for copper or soft steel pipe with 1.0 mm wall thickness. Max. operating temperature 120°C, max. operating pressure 10 bar.

Compression fitting for COPPER and SOFT STEEL pipe.
Consisting of compression nut, compression ring and support insert.
For valves with internal thread.

	Valve size	Pipe dimension	Part number	Pcs/ pack
	3/8" (DN10)	12 mm	FIG3/8CSS12	1
	1/2" (DN15)	12 mm	FIG1/2CSS12	1
	1/2" (DN15)	14 mm	FIG1/2CSS14	1
	1/2" (DN15)	15 mm	FIG1/2CSS15	1
	1/2" (DN15)	16 mm	FIG1/2CSS16	1
	1/2" (DN15)	18 mm	FIG1/2CSS18	1
	3/4" (DN20)	18 mm	FIG3/4CSS18	1


NOTE: Support inserts have to be used for copper or soft steel pipe with 1.0 mm wall thickness. Max. operating temperature 120°C, max. operating pressure 10 bar.

Compression fitting for MULTILAYER pipe.
Consisting of compression nut, compression ring and support insert.
For valves with internal thread.


	Valve size	Pipe dimension	Part number	Pcs/ pack
	1/2" (DN15)	16 mm	FIG1/2M16X2	1

NOTE: Max. operating temperature 90°C, max. operating pressure 10 bar.

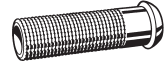
Reduction piece

	1" pipe > 1/2" valve	VA6290A260
	1 1/4" pipe > 1/2" valve	VA6290A280
	1" pipe > 3/4" valve	VA6290A285
	1 1/4" pipe > 3/4" valve	VA6290A305

Radiator tailpiece with thread up to collar


	for valves DN10 (3/8")	VA5201A010
	for valves DN15 (1/2")	VA5201A015
	for valves DN20 (3/4")	VA5201A020

Extended radiator tailpiece, nickel-plated, to be shortened as required


	3/8" x 70 mm (for DN10) thread approx. 50 mm	VA5204B010
	1/2" x 76 mm (for DN15) thread approx. 65 mm	VA5204B015
	3/4" x 70 mm (for DN20) thread approx. 60 mm	VA5204B020

Valve Accessories


Manual handwheel cap

	Pre-settable, with integrated locking device	VA2200D001
---	--	------------

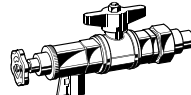
Pressure cap – for shutting off valves on radiator outlet

	for valves DN10 (3/8")	VA2202A010
	for valves DN15 (1/2")	VA2202A015
	for valves DN20 (3/4")	VA2202A020


Sealing ring for pressure cap

	for valves DN10 (3/8")	VA5090A010
	for valves DN15 (1/2")	VA5090A015
	for valves DN20 (3/4")	VA5090A020


Service tool to replace valve insert

	for all sizes	VA8200A001
---	---------------	------------


Precision pre-setting key

	for all VS and FS type valves	VA8201FV03
---	-------------------------------	------------

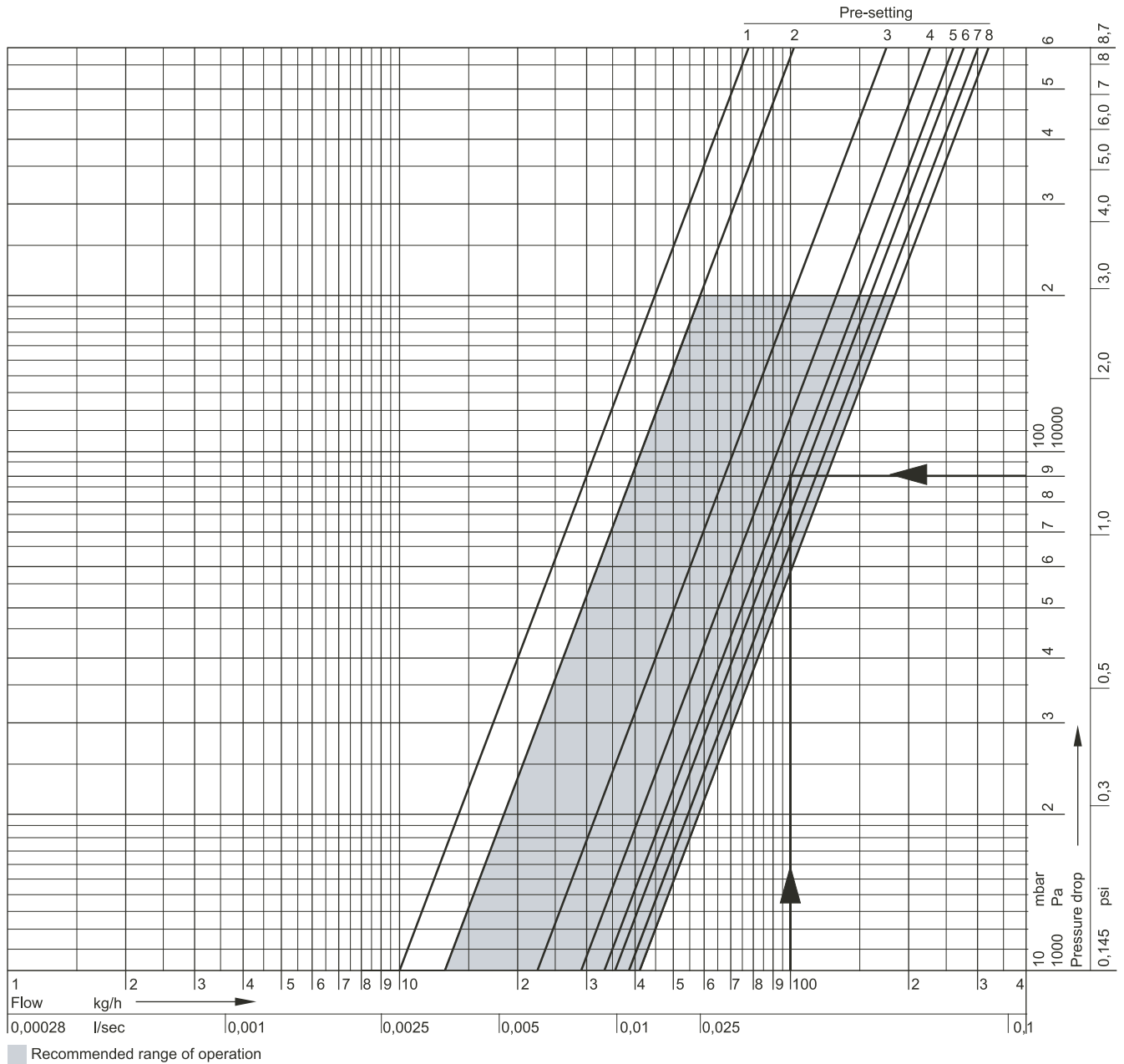
Pre-setting key

	for all VS, V, FS and FV type valves	VA8201FV02
---	--------------------------------------	------------

Replacement valve insert

	VS type	VS1200VS01
---	---------	------------

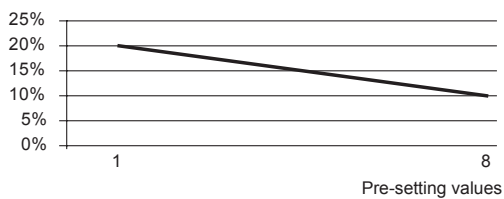
Flow Diagram (based on 2K)



Pre-setting	1	2	3	4	5	6	7	8
xP = 1K (m ³ /h)	0.10	0.12	0.15	0.18	0.19	0.20	0.20	0.20
xP = 2K (m ³ /h)	0.10	0.13	0.22	0.29	0.33	0.36	0.38	0.41
k _v -value (m ³ /h)	0.10	0.15	0.25	0.35	0.45	0.57	0.65	0.75
c _v -value (m ³ /h)	0.12	0.17	0.29	0.41	0.52	0.66	0.75	0.87

Pre-setting 8 = flush position, set by factory

Tolerances for Pre-setting Values



Design example

- Given: Flow 100 kg/h
- Required: Pre-setting for a required pressure loss $\Delta p = 90 \text{ mbar} = 9\,000 \text{ Pa}$ with a P-band of 2K
- Solution: The required pressure loss is found at the intersection of the flow line with the line for the chosen valve performance P=2K
- Result: Presetting 5

Environmental and Combustion Controls

Honeywell GmbH
Hardhofweg
74821 MOSBACH
GERMANY
Phone: +49 (6261) 810
Fax: +49 (6261) 81393
<http://ecc.emea.honeywell.com>

Manufactured for and on behalf of the Environmental and Combustion Controls Division of Honeywell Technologies Sàrl, Z.A. La Pièce 16, 1180 Rolle, Switzerland or its Authorized Representative.

ENOH-2103GE25 R0115
Subject to change • All rights reserved
© 2015 Honeywell International Inc.

Honeywell

 **AutomatikCentret**

Strandvejen 42 • Saksild • 8300 Odder
86 62 63 64 • www.automatikcentret.dk
info@automatikcentret.dk